

INSTALLATION INSTRUCTIONS

# Acclaim - LED Retrofit Kit

## ATEX & IECEx

**Important:** Please read the following instructions carefully prior to installation or maintenance of this equipment.

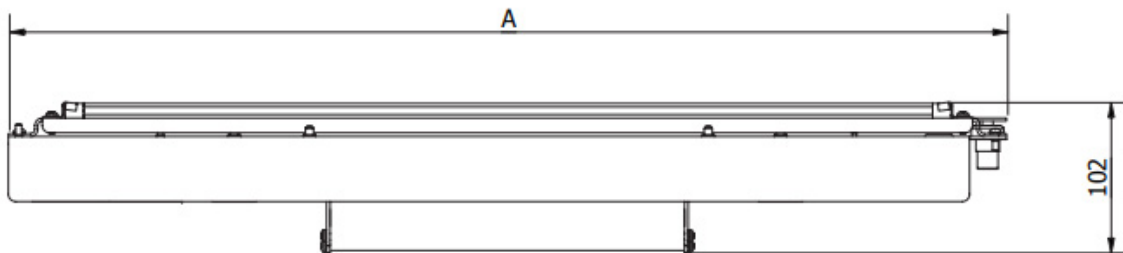
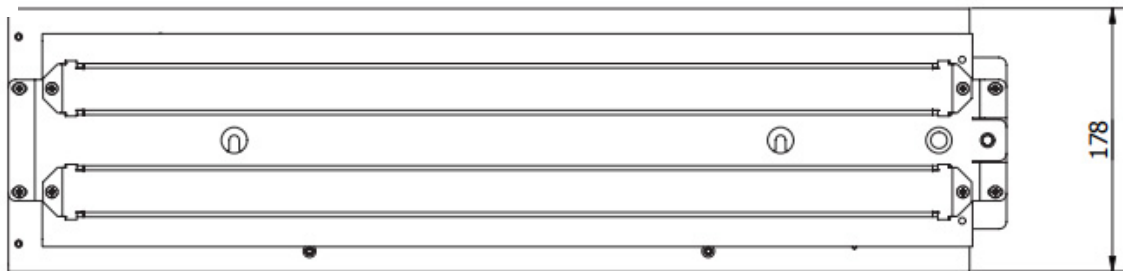

Model	A
02L	676
04L	1276



### 1.0 Introduction – Acclaim LED Retrofit kit

This installation leaflet shows the steps required to upgrade an existing Acclaim fluorescent fitting to an LED alternative and should be used alongside the Acclaim LED IOM supplied. The retrofit gear tray should only be fitted and operated as outlined and must only be used inside our Ex certified Acclaim body. Failure to do so will invalidate the product certification.

All work must be carried out by competent/ qualified personnel along with rigorous inspection of the existing enclosure prior to retrofit. All work should be documented and kept on file detailing dates, old and new serial numbers and persons responsible.

## 2.0 Tools Required

The following tools are required to complete the following work:

- 3mm and 5mm Flat Blade Screwdriver
- PZ2 Pozidrive Screwdriver

## 3.0 Installation Instructions

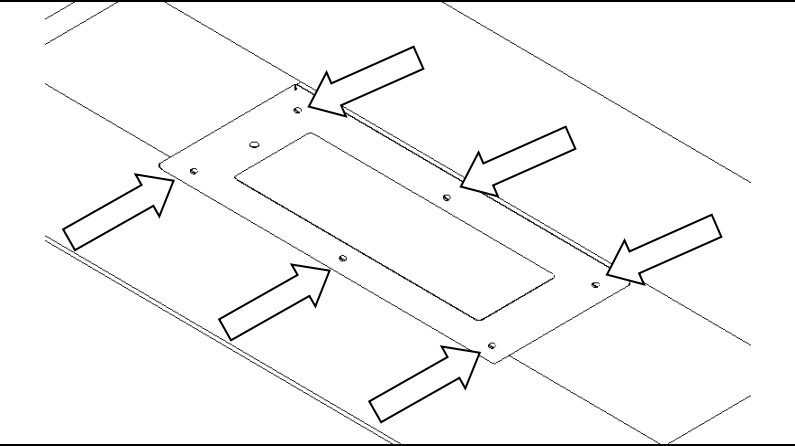
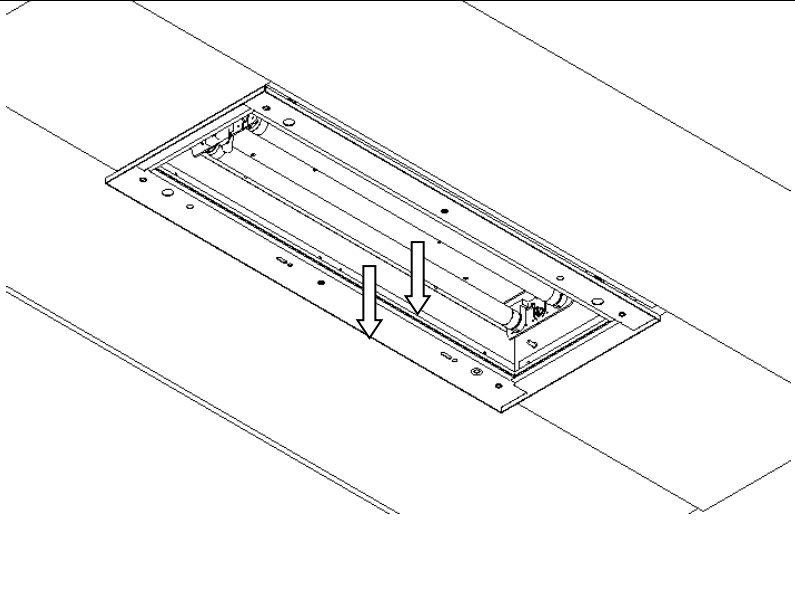
1.		<p><b>TOOL: 5mm FLAT BLADE</b> LOOSEN DIFFUSER SCREWS AND DROP DIFFUSER (CAN BE REMOVED TO IMPROVE ACCESS).</p>
2.		<p>REMOVE LAMPS</p>

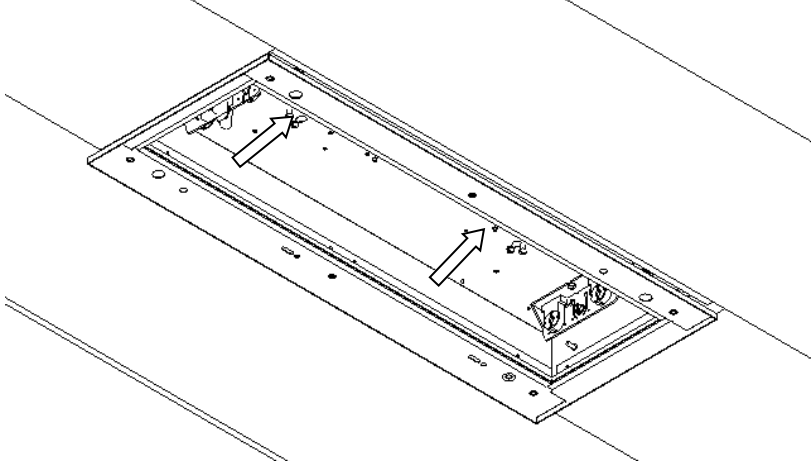
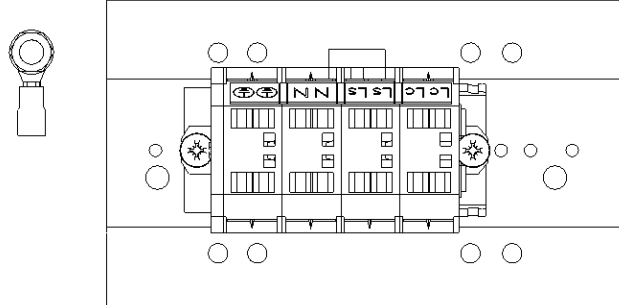
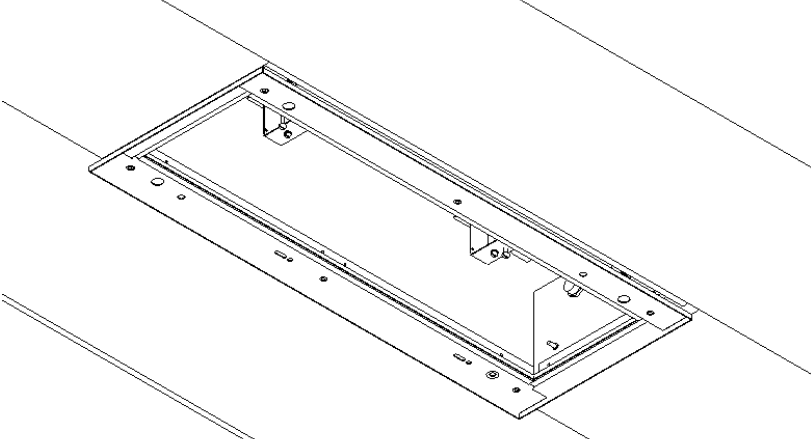
<p>3.</p>		<p><b>TOOL: 5mm FLAT BLADE</b>          LOOSEN 2-OFF SCREWS          SECURING GEAR TRAY. SLIDE          GEAR TRAY IN KEYHOLE SLOTS          AND LOWER ONTO HANGING          STRAPS.</p>
<p>4.</p>		<p><b>TOOL: 3mm FLAT BLADE</b>          DISCONNECT GEAR TRAY          WIRES FROM MAINS TERMINAL          BLOCK IN BODY          AND REMOVE GEAR TRAY          FROM HANGING STRAPS.</p> <p><b>TOOL: P2Z SCREWDRIVER</b>          REPLACE EXISTING HANGING          STRAPS WITH REPLACEMENTS          SUPPLIED.</p>
<p>5.</p>		<p><b>INSPECTION: ENSURE THAT          ALL COMPONENTS, SEALS AND          ENTRIES ARE INSPECTED          THOROUGHLY FOR SIGNS OF          DAMAGE, DEGRADATION,          LEAKAGE ETC BEFORE          CONTINUING. THIS IS          ESSENTIAL FOR SAFE USE.          ANY ISSUES NOTED SHOULD          BE REPORTED PRIOR TO          POWER BEING RESTORED TO          THE FITTING.</b></p>

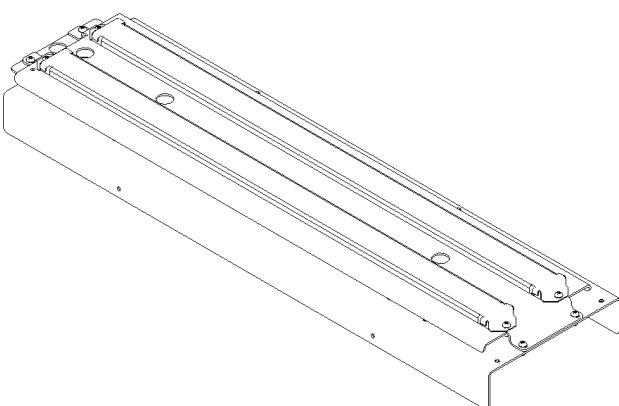
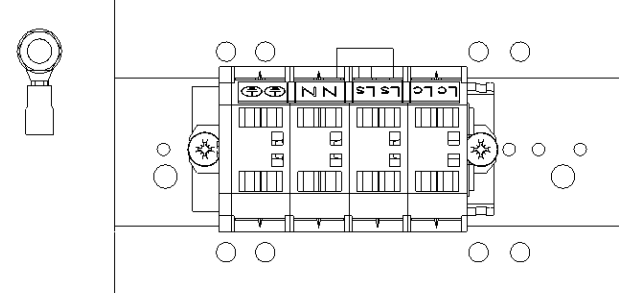
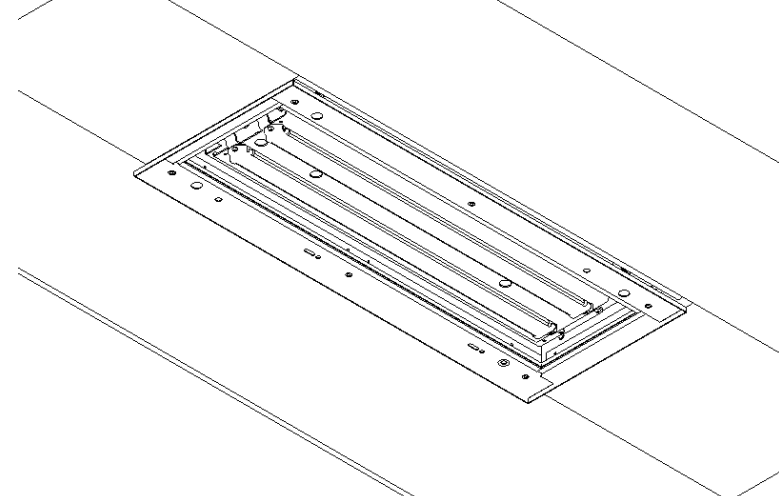

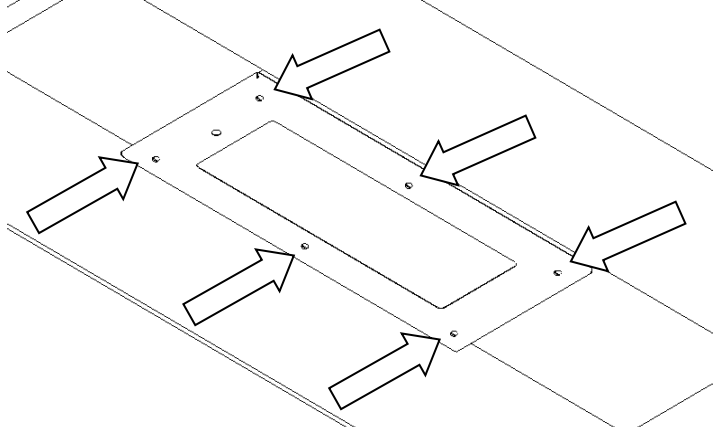
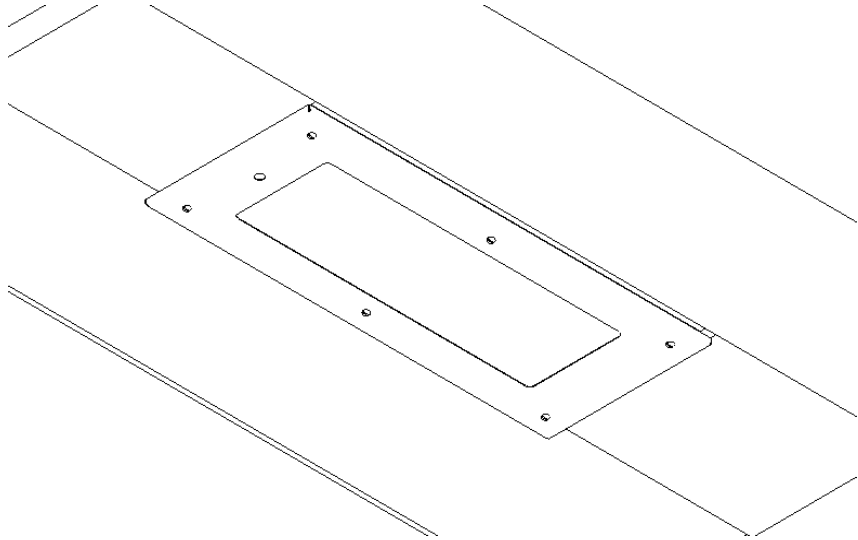
<p>6.</p>		<p>COLLECT RETROFIT GEARTRAY.</p>
<p>7.</p>		<p><b>TOOL: 3mm FLAT BLADE</b>  ATTACH GEAR TRAY TO HANGING STRAPS AND CONNECT DRIVER WIRES TO TERMINAL BLOCK IN BODY.</p> <p><b>REFERENCE WIRING DIAGRAM TO ENSURE CORRECT CONNECTIONS ARE MADE. EMERGENCY VERSIONS ARE SUPPLIED WITH THE BATTERY DISCONNECTED.</b></p>
<p>8.</p>		<p><b>TOOL: 5mm FLAT BLADE</b>  LOCATE GEAR TRAY USING KEYHOLE SLOTS AND TIGHTEN 2-OFF SCREWS FULLY.</p>

9.		<p><b>TOOL: 5mm FLAT BLADE REFIT DIFFUSER</b></p>
10.		<p>ADDITIONAL NAMEPLATE LABEL CAN BE ADHERED TO FITTING ONCE ALL WORK IS COMPLETE AND APPROVED. USE A DAMP CLOTH TO CLEAN AREA BEFORE FITTING LABEL. <b>ORIGINAL LABEL MUST ALSO BE LEFT INTACT AND VISIBLE FOR TRACEABILITY REASONS.</b></p> <p><b>FINISHED PRODUCT: POWER CAN BE RESTORED.</b></p>



To comply with the Waste Electrical and Electronic Equipment directive 2012/19/EU the apparatus cannot be classified as commercial waste and as such must be disposed of or recycled in such a manner as to reduce the environmental impact.

**Chalmit Lighting is a leading supplier of Hazardous Area lighting products**

	<p><b>CHALMIT LIGHTING</b> PO Box 5575 Glasgow, G52 9AP Scotland</p>	
<p>Telephone: +44 (0) 141 882 5555 Fax: +44 (0) 141 883 3704 Email: info@chalmit.com Web: www.chalmit.com</p>	<p>Registered No: 669157 Registered Office: Cannon Place 78 Cannon Street London EC4N 6AF UK</p>	

**For technical support, please contact: techsupport@chalmit.com**

Note: Chalmit Lighting reserves the right to amend characteristics of our products and all data is for guidance only.

